



***Instruction Manual***

***CAV-201AS  
2-1 A/V Switch***

Another Exciting Product From

**DIGISTREAM PTE LTD**

21 Kaki Bukit View, Kaki Bukit Tech Park II, Singapore 415957

Tel: 6-783-1111

Fax: 6-742-9388

E-mail: [pdt-sales@digistream.com.sg](mailto:pdt-sales@digistream.com.sg)

Website:

[www.digistream.com.sg](http://www.digistream.com.sg)

---

**Contents**

---

<b>Features</b>	.....	1
<b>Introductions</b>	.....	2
<b>Connections</b>	.....	3
<b>How it works</b>	.....	5
Cascading:	.....	7
<b>Specifications</b>	.....	9

---

## Features

- Auto detects and auto selects from 2 sets of input signals
- Easy to use
- Use RCA jacks for A/V input and output ports
- Compact
- Light weight (approx. 93.6g)
- Modular
- Operates on 12V DC
- Cascade to form multi-to-1 A/V Switch

---

## Introduction

The 2-1 AV Switch (CAV-201AS) is an easy to use automatic audio/video signal-selecting device. It is compact and operates on a 12V DC power. To make it easy to use, the input and output ports comprise of only RCA jacks. It can automatically detect and switch between 2 sets of A/V inputs and outputs the selected signals to the output devices (eg. speakers and displays etc) of your A/V equipment. With its modularity, if desired, the A/V Switch can cascade with another A/V Switch to form multi-to-1 A/V Switch such that you can have the output signals auto-selected from multiple sets of input signals.

---

## Connections

The 2-1 A/V Switch (CAV-201AS) is as shown in the following picture. One side of the A/V Switch consisted of the power connector and the output ports while the other side consisted of the input ports. These input ports are divided into 2 groups, the default ports and the triggering ports.

To make the A/V Switch into operation, connect the A/V output signals of your A/V equipments (eg. DVD, DVB set top box etc) to the input ports of the A/V Switch. The signals with higher priority should be connected to the triggering ports and the signals with lower priority connected to the default ports. This arrangement will allow the lower priority signals to be switched off when there is a presence of higher priority signals. See the next section **How it works** for more understanding. The output ports of the A/V Switch should be connected to the output devices (eg. speakers and displays) of your A/V equipment. Finally, plug the cable provided to the Power connector (DC 12V) and connect the red wire to the ACC line of the vehicle and the black wire to the GND line. The A/V Switch is now ready for operation.

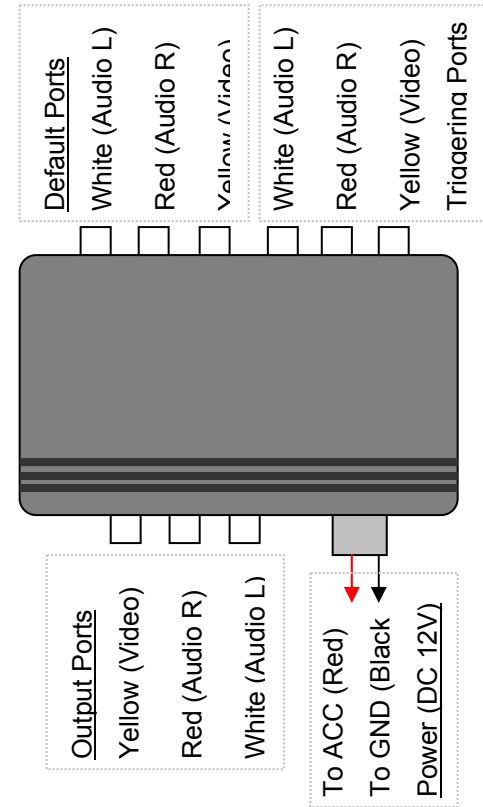

## How it works

With the A/V Switch connected as per described in the **Connections** section above, the system should work as follows.

- Case 1: When there is no signal at the input ports (both default and triggering ports), there is no signal at output ports.
- Case 2: When there are signals at default ports and no signals at triggering ports, output ports reproduce signals from default ports.
- Case 3: When there are no signals at default ports and there are signals at triggering ports, output ports reproduce signals from triggering ports.
- Case 4: When there are signals at both default ports (lower priority) and triggering ports (higher priority), output ports reproduce signals from triggering ports (higher priority).

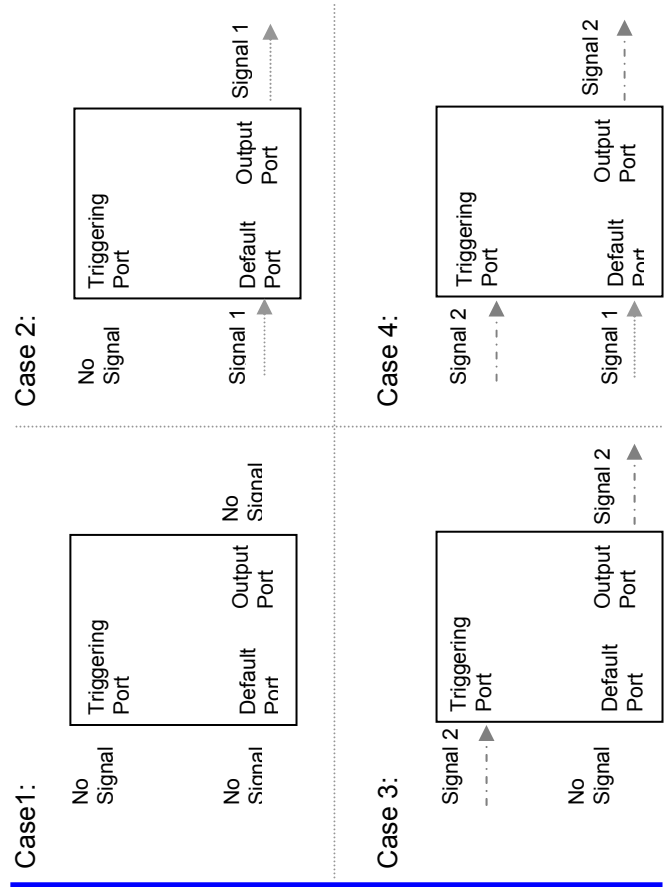

Cascading:

The A/V Switch can also be cascaded to configure it into a multiple input (multi-to-1) A/V Switch. To cascade, connect the output port of the higher priority module to the triggering port of the lower priority module. In such case, the signals from the triggering port of the higher priority module has the highest priority follow by the signals from the default port of the higher priority module and then the signals from the default port of the lower priority module. The below figure and table summarise the cascading operation.

If required, more modules can be cascaded.

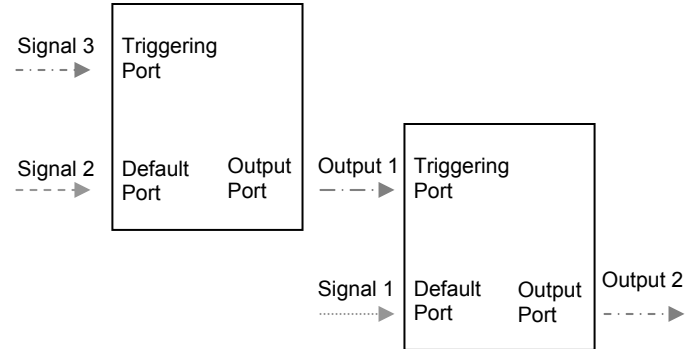

Signal 3	Signal 2	Signal 1	Output 1	Output 2
No	No	No	No	No
No	No	Yes	No	Signal 1
No	Yes	No	Signal 2	Signal 2
No	Yes	Yes	Signal 2	Signal 2
Yes	No	No	Signal 3	Signal 3
Yes	No	Yes	Signal 3	Signal 3
Yes	Yes	No	Signal 3	Signal 3
Yes	Yes	Yes	Signal 3	Signal 3

---

## Specifications

Operating Power	DC 12 V
Power Consumption	Max 1.2 W
Dimension	100mm (L) x 32mm (H) x 75mm (D)
Weight	Approx. 93.6 grams
Operating Temperature	-10°C ~ +70°C

Default Port	Connector	Impedance
Audio (L/R)	2 x RCA Jacks	Over 10 K $\Omega$
Video	1 x RCA Jack	75 $\Omega$
Triggering Port	Connector	Impedance
Audio (L/R)	2 x RCA Jacks	Over 10 K
Video	1 x RCA Jack	75 $\Omega$
Output Port	Connector	Impedance
Audio (L/R)	2 x RCA Jacks	Over 10 K $\Omega$
Video	1 x RCA Jack	75 $\Omega$